

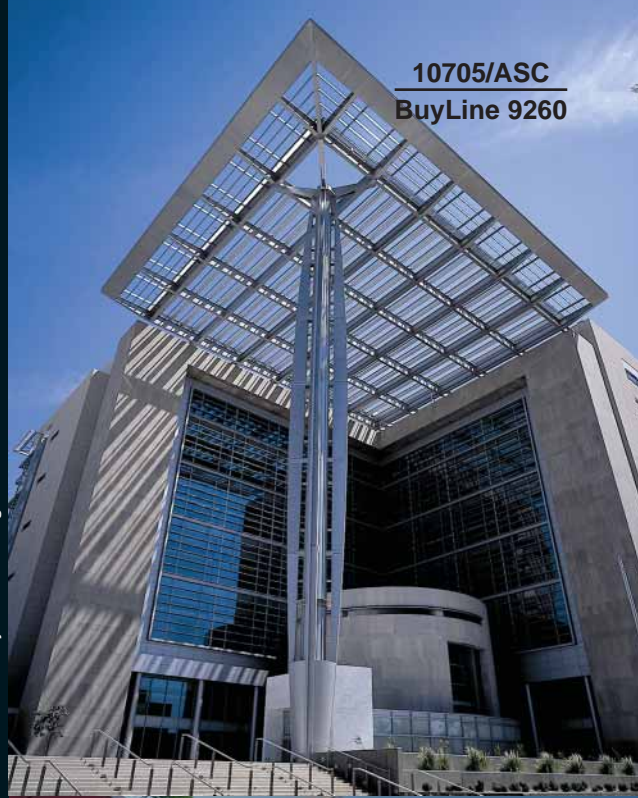

10705/ASC
BuyLine 9260

Cannon Dworsky/HCA and Langdon Wilson



Architectural Sun Control

- Climate Control Facades
- Cantilevered Sunshades
- Trellis & Canopies
- Suspended Sunshades
- Monumental Venetian Blinds
- Kinetic Systems
- Lightshelves
- BIPV Sunshades
- Natural Daylighting Systems
- Architectural Metal

Trivers Associates



Bernardo Willis Architects



As the leader in Architectural Sun Control, ASCA, Inc. provides efficient and cost effective solutions to both traditional and custom designs. Profiled in this catalogue are select samples of ASCA, Inc.'s portfolio, with additional compositions available on www.ASCA-design.com.

Designers, detailers, and specification writers may access our public website to view numerous project profiles, case studies, and specific model details. Sample compositions, their related details and associated specifications, are available to the entire architectural community.

Existing project clients may enter the site through password protected access to proprietary details, mock-up photographs and fabrication status via the FabTrac system. ASCA's web based client services are another example of our ongoing partnering approach to project team members and our accountability as the leading sun control manufacturer.

Visit us on the web at www.ASCA-design.com.



Climate Control Facades

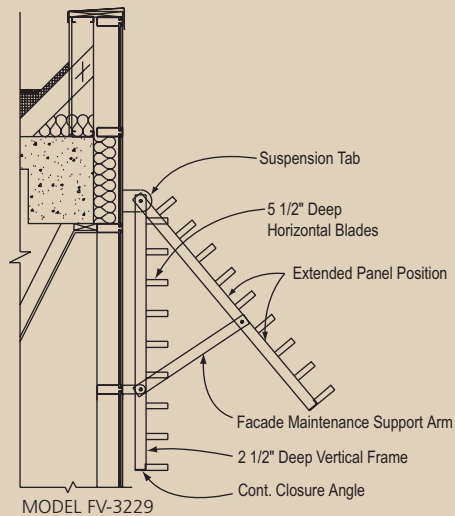

Architect: Leo A Daly Company
 GBI Laboratory Annex

From passive to dynamic solar control, ASCA climate control facades create a practical and versatile sun control system, while simultaneously providing a striking architectural and individual statement.

Diffusing direct solar radiation at the exterior of the building envelope not only reduces mechanical loading, but also increases the health and productivity within the interior environment.

Hinged panels or integrated catwalks provide sensible solutions to fenestration maintenance, while overall functionality reduces heat and glare by as much as 80%.¹



Architect: NBBJ Sports and Entertainment
 Dodge Phoenix Theater



Architect: Kohn Pedersen Fox
 Gannett/USA Today

1. ASHRAE Fundamental Handbook

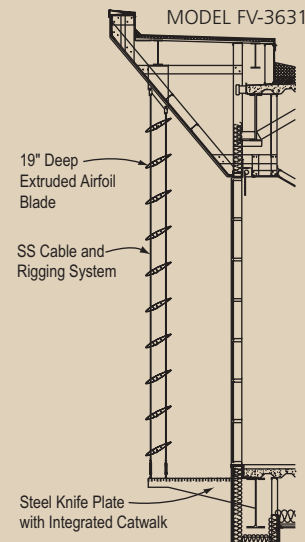

Cantilevered Sunshades

Sustainable designs, whether wholly custom or historically repetitive, are pre-engineered to simultaneously facilitate the strictest aesthetic and field requirements.

Whether a traditional or custom cantilever, ASCA product designers maintain the architectural intent while minimizing cost and apparent complexity.

Outriggers may be virtually of any style desired, including decorative cutouts of standard or proprietary shapes.

Component configurations, spacing, slope and specific arrangements may be interchanged to suit visual, engineering and solar filtering needs.



Architect: Stanley Beaman & Sears
North Georgia College & State University

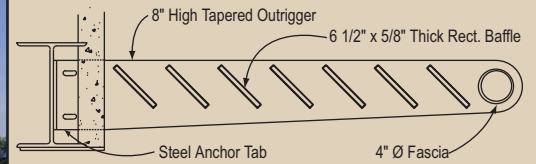

MODEL CH-2752

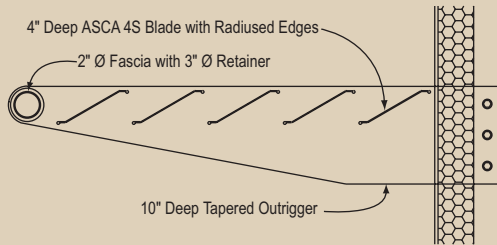

MODEL CH-2560



Architect: Rafael Architects | KSHB-TV



Architect: Trivers Associates
Family Care Health Center



Architect: Frye Gillan Molinaro
Northbrook Library

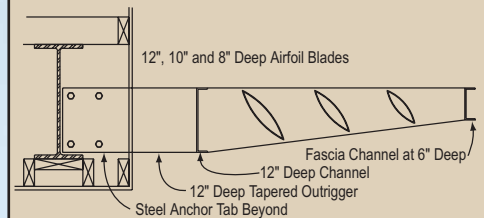

MODEL CH-2732

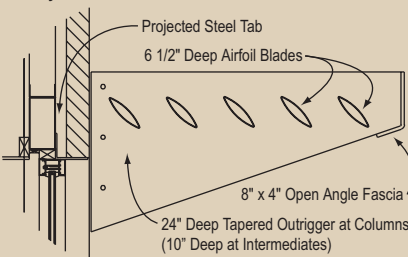
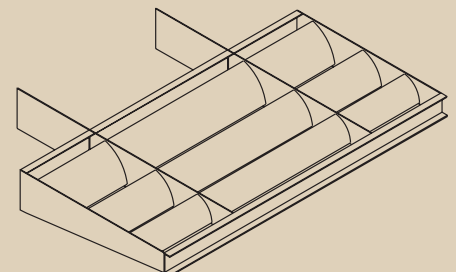

MODEL CH-3396

For component profiles, see page 11 or visit www.asca-design.com.

Trellis & Canopies



Architect: Cannon Dworsky/HCA and Langdon Wilson
Las Vegas Courthouse



Architect: Richard Meier

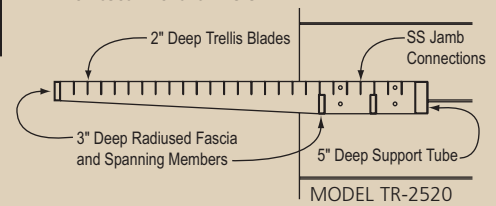

Architectural trellis and canopies create a single and self-sustaining architectural entity for any project or site.

From radiused major to mild elements to perforated blades spanning up to 7 meters for the Las Vegas Courthouse, ASCA's proven versatility in facilitating architectural component needs provides a constant variety of design possibilities.

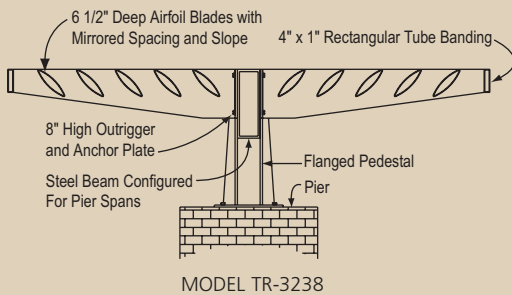

MODEL TR-3238

ASCA systems provide lasting and maintenance-free shading structures, whether a monumental enhancement to the core building design or a free standing adornment to pedestrian areas.



Architect: Hawkins & Hall Architects
Embry Riddle University



Architect: Wallace, Roberts, and Todd
Susquehanna Commerce Center



Architect: Bernardo Wills Architects
Modern Electric Water Company

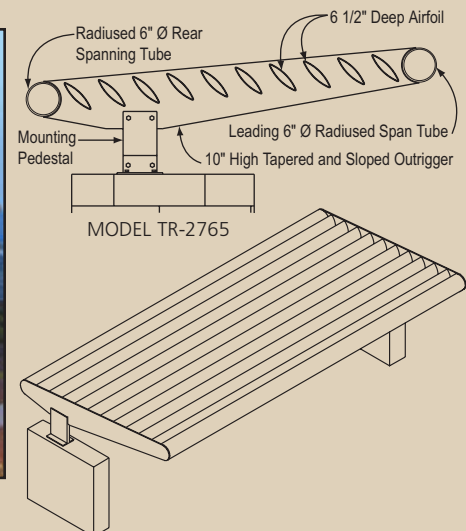

MODEL TR-2765

Suspended Sunshades

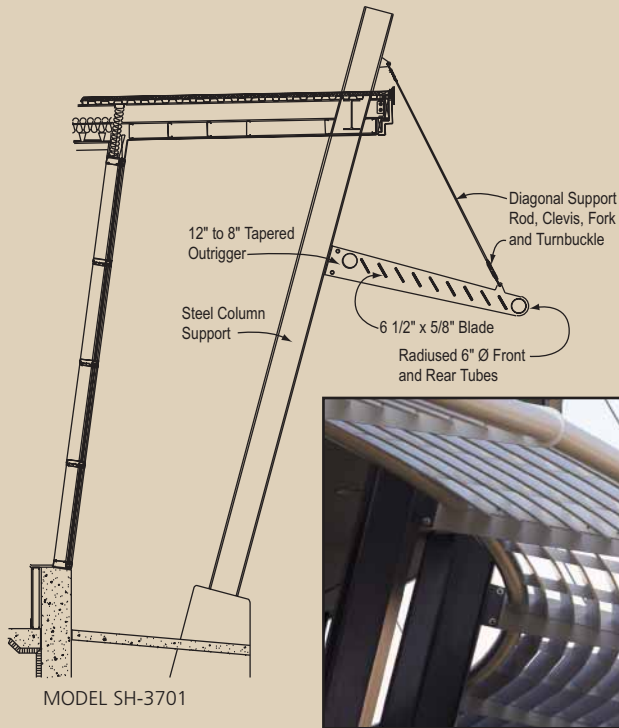

Architect: 3 I Engineering
Bristol-Myers/Mead Johnson Fitness Center



Architect: Backen Arrigoni & Ross
Sun Microsystems

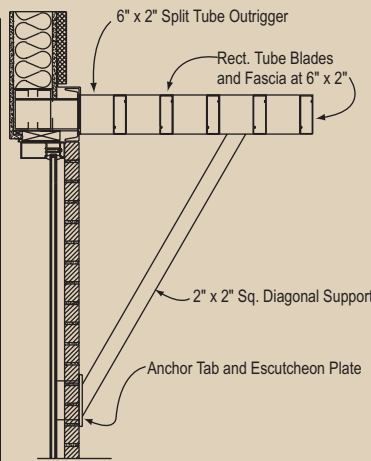

Limited only by the inquiring imagination and engineering criteria, ASCA solar control systems can be adapted to any design condition.

Suspended or supported applications are facilitated with fully adjustable capabilities to meet the most unexpected field tolerances.

Support elements may consist of either natural stainless steel or finished aluminum. Architecturally designed suspension tabs and additional medallions are usually desired.

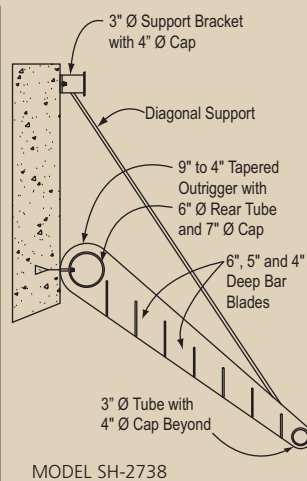

Architect: Davidson Kuhr Architects | Montana State University

Monumental Venetian Blinds



Architect: AIM Architects
Environmental Technology Center (SSU)

The Sunshield line is a 3" deep internal or external venetian blind, designed to be controlled either via an integrated electrical motor or manual crank operation. Electrical operation may group multiple blinds to adjust in concert with each other or provide independent room control; in either case, the horizontal slats are rotated for optimal daylighting effectiveness.



Architect: J. Woodson Rainey Jr.
Citi Corp Building, Schlumberger Levels

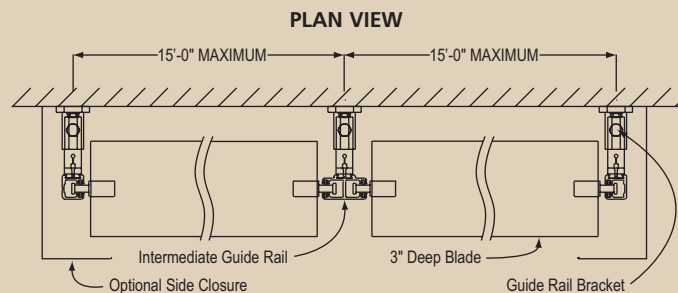
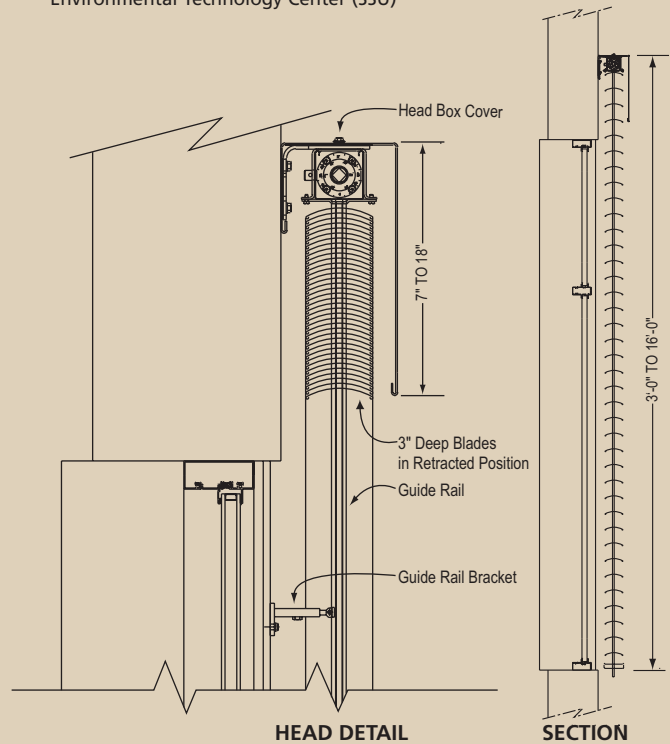

Sunshield operation allows for the series of slats to be fully lowered from their continuous housing or recessed pocket at the head of the window. Once in place, the horizontal vanes may be adjusted according to desired light levels, or fully closed for privacy. Anemometers may be provided with electrical systems to automatically retract the blinds under predetermined wind conditions.

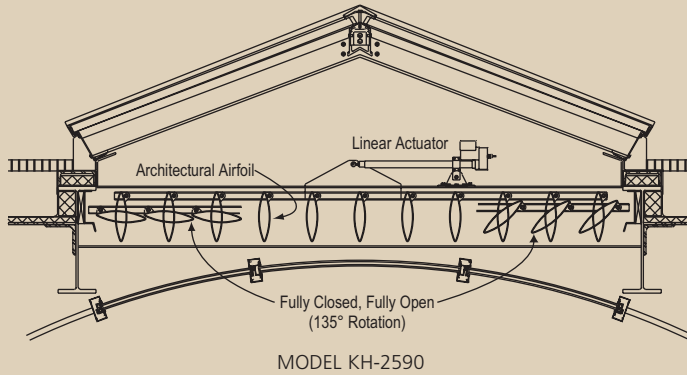

Architect: J Kleihues/A. Epstein & Sons
Museum of Contemporary Art

Most artists, curators and architects believe that artwork should be presented and viewed under the same lighting conditions as they were created.

The system quickly and consistently has shown to effectively light the picture walls naturally in a controlled and uniform manner, providing accurate color rendering.² Dynamic systems may be energized through interactive automated software to a simple electrical toggle control.



2. Mojtaba Navvb, LD&A



Architect: H.P. Ammann, P. Baumann
Lucerne Station

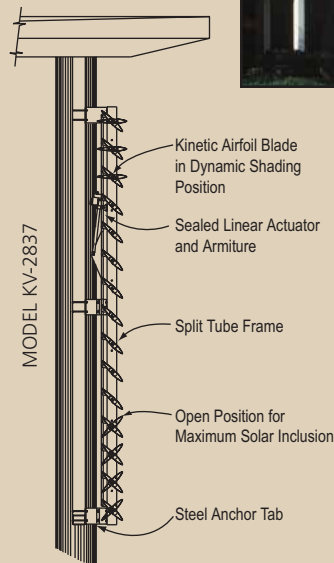

Architect: Good Fulton & Farrell Architects
Hockaday School

No longer limited to museums and galleries, intelligent daylight control is now available to every designer and project. ASCA's kinetic systems may be utilized with skylights, in atriums and in other expansively glazed areas where light, reflection or heat build-up needs to be monitored.

ASCA

Lightshelves

Lightshelves are utilized to reflect natural sunlight deep into perimeter spaces, providing uniform and natural daylight distribution. Exterior applications not only accomplish the intended function of a lightshelf, but also serve as a sunshade for the windows and occupant area below.

Daylighting systems are designed to increase illumination within the building interior and significantly reduce energy light costs. Under case studies, the greatest energy savings (46%) were achieved with interior lightshelves when used in correlation with dimming ballasts.³

Interior lightshelves may be provided in a variety of arrangements including, but not limited to, adjustable panels for reflection optimization and hinged units that provide for convenient and periodic cleaning access.

3. Floyd, Florida Solar Energy Center

Architect: Gould Evans/Croxton Collaborative Architects | Rinker Hall, University of Florida



LEED™ Gold Building Design

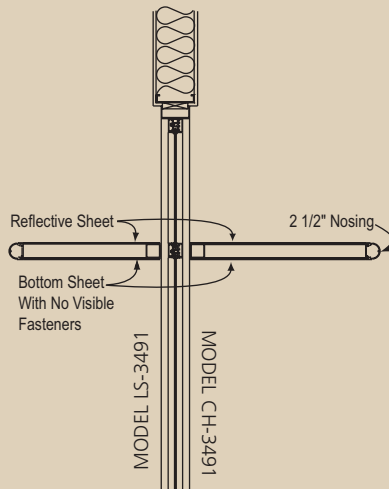

Architect: Group 70 | Iolani School



Architect: Smith Group
Mt. Zion Outpatient Cancer Center (UCSF)



Architect: Perez-Green Architects
Wendell P. Williams Elementary School

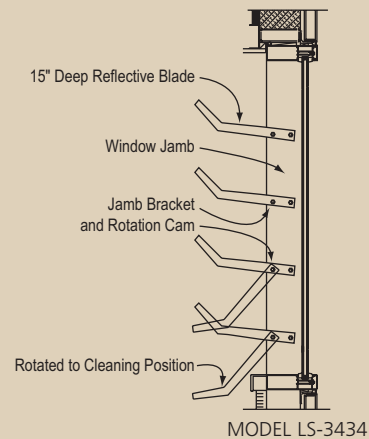

MODEL LS-3434

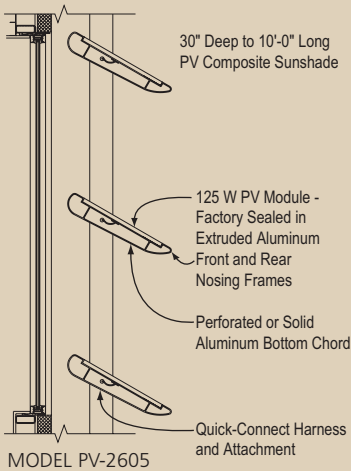

ASCA, Inc. offers a series of Building Integrated Photovoltaic (BIPV) Sunshade compositions for commercial and institutional project clientele. Seamlessly integrated within our architectural features, ASCA PV Sunshade modules may be either crystalline or amorphous and deliver an average of 125 watts for every 4'-0" of sunshade, under optimal performance conditions. ASCA BIPV Sunshades provide the flexibility of individual architectural sun control design and function, while incorporating the most advanced solar module technology available.



Environmentally Aware Design

From ASCA ornate static compositions to dynamic kinetic systems, to daylighting elements and solar panel sunshades, ASCA systems may inherently contribute to any LEED™ design project for Daylight and Views, Controllability of Systems, Recycled Content and Renewable Energy.

ASCA, Inc. products are not only environmentally responsible by their conscientious development; they are designed, engineered and manufactured to maintain the life span of any progressively designed building.



Client Design Services

- | | |
|--------------------------|----------------------|
| Concept/Schematic Review | Budgetary Evaluation |
| Value-Added Engineering | Feasibility Analysis |
| Specifications/Details | Design Development |

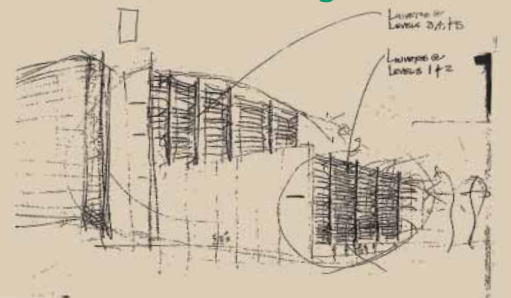

Architect: Ford Farwell Mills & Associates

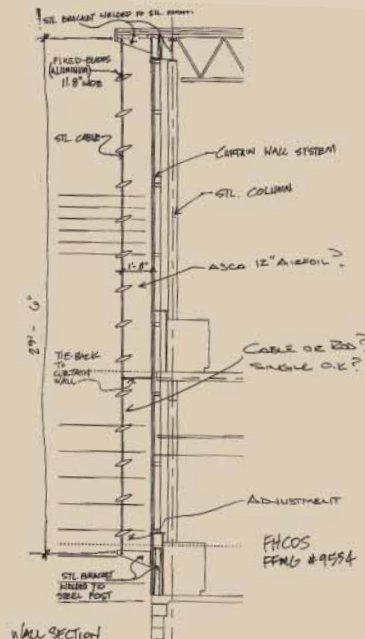

Architect: Bruder DWL

Reflexive design and manufacturing philosophies allow our product engineers to collaborate in the evolution of any application. Whether during the schematic, construction documentation, design build phases or even when value-added engineering is required, ASCA leads product concepts to their reality.

Sample Configurations

Cantilevered Models

(3/8"=1'-0")

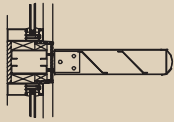

CH-3248

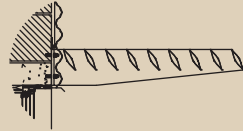

CH-3471



CH-3063

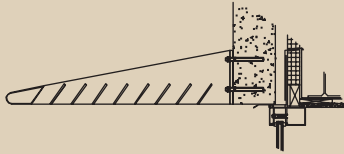

CH-3414

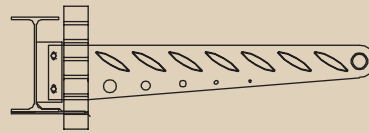

CH-2740

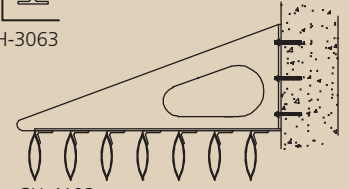

CH-4103



CH-2895

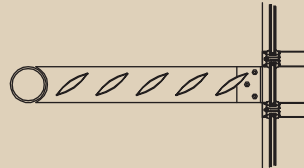

CH-3383

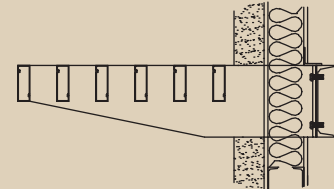

CH-3470

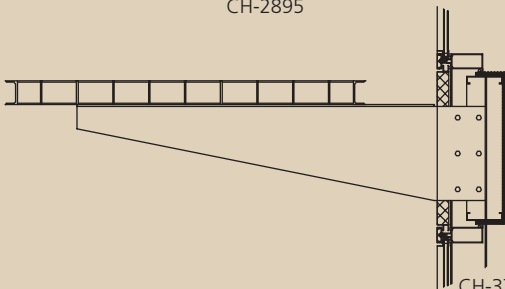

CH-3778

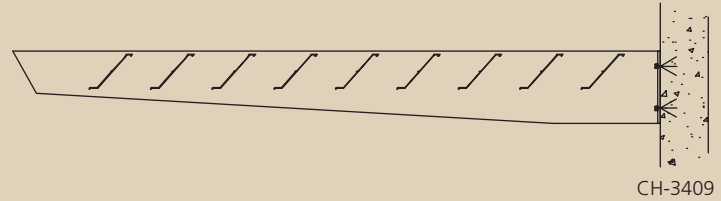

CH-3409

Suspended / Supported Models

(3/8"=1'-0")

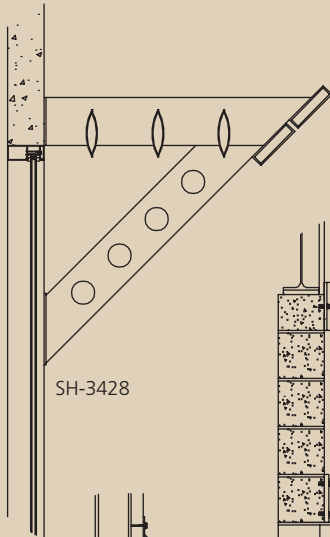

SH-3428

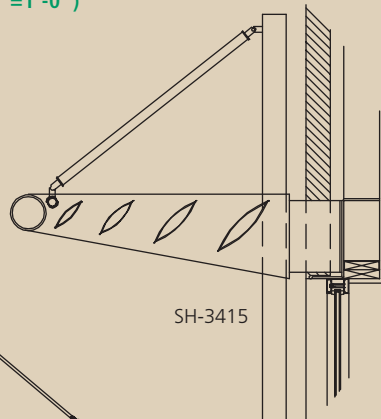

SH-3415

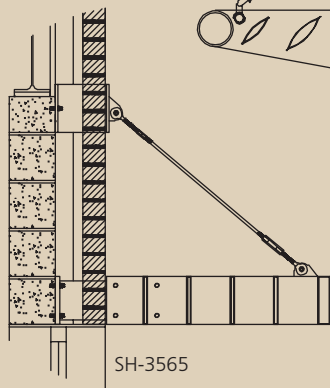

SH-3565

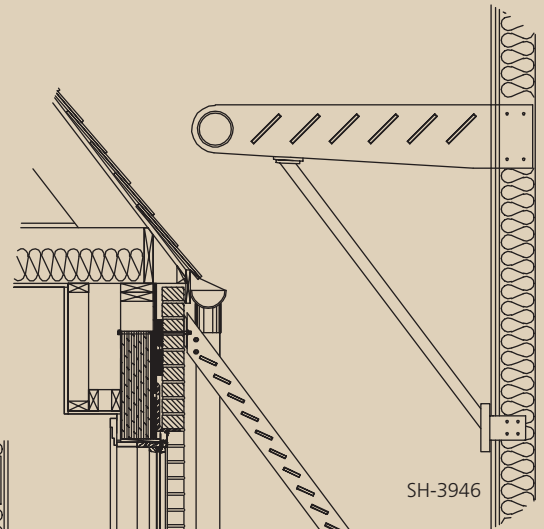

SH-3946

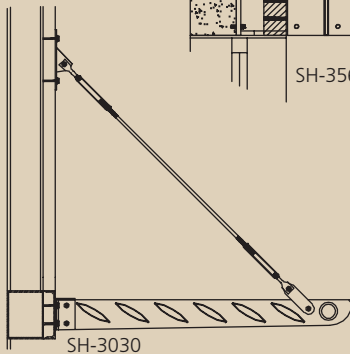

SH-3030

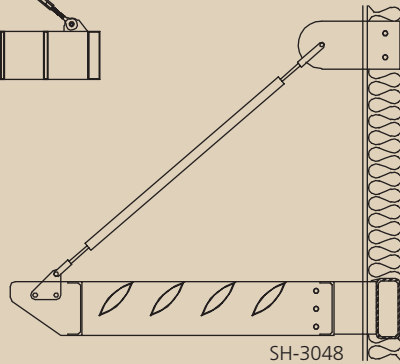

SH-3048

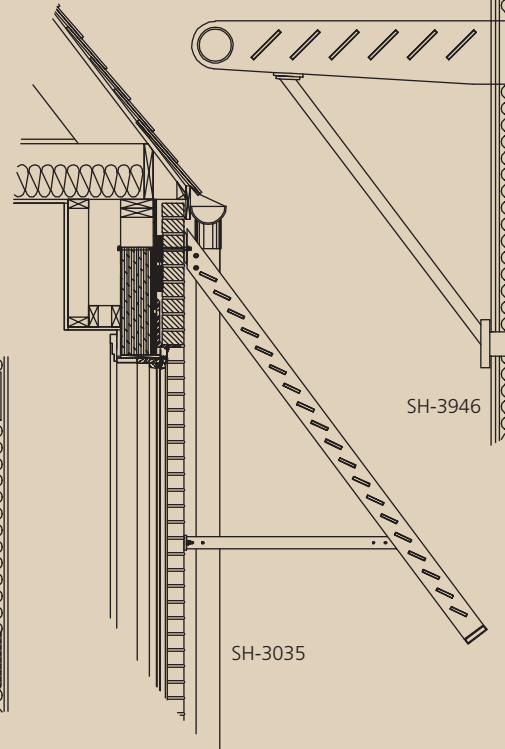

SH-3035

Visit www.asca-design.com for:

Photographs • Details • Case Studies • Specifications • Client Login • FabTrac

For additional Sample Profiles, visit www.ASCA-design.com

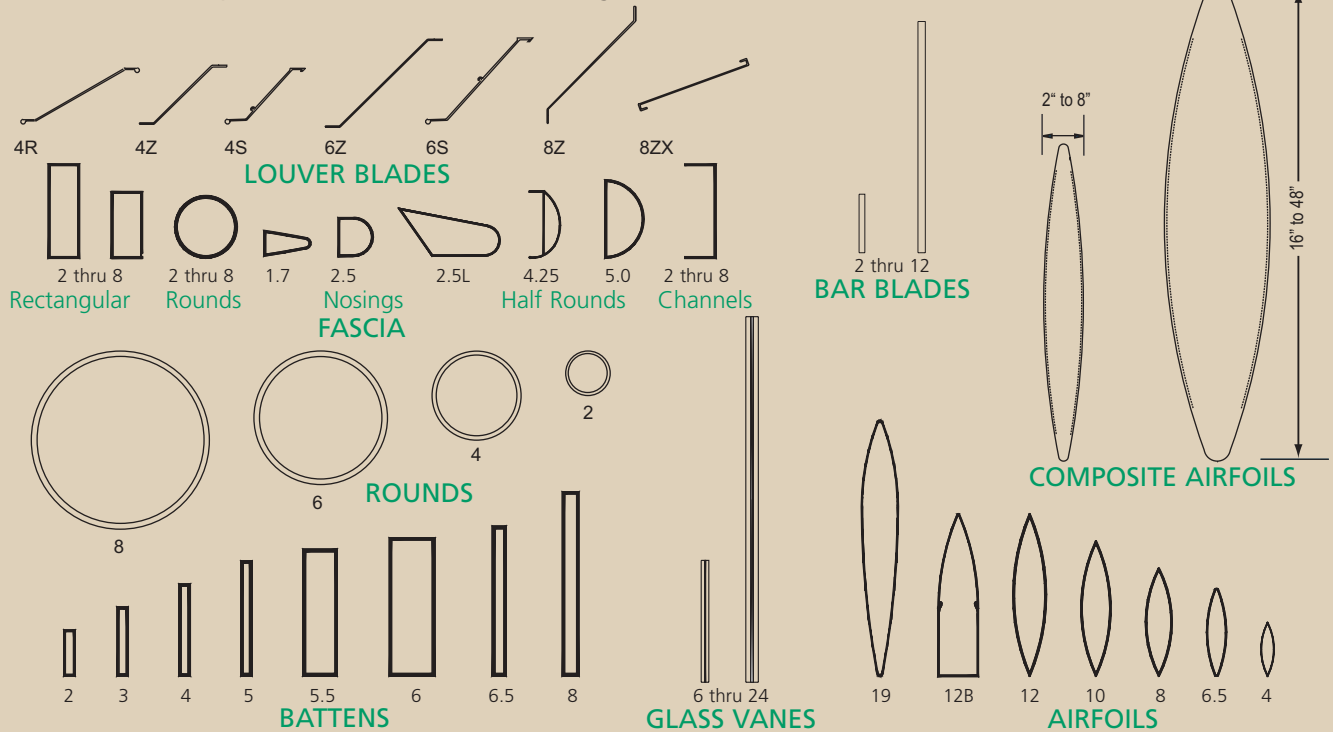

Configurations depicted are a small sampling of standard shapes and are illustrated for terminology and general guideline purposes only. The ever increasing and dynamic depth of component shapes is best explored by first communicating the design intent.

Architectural Sunshades

10705 – External Sun Control Devices • 10730 – Daylighting Systems • 10240 – Grilles & Screens

PART 1 GENERAL

1.01 Summary

- A. This section includes products to assist in controlling the effects of the sun.
- B. Related Sections: The following sections contain requirements related to this section:
 1. Section 05500 "Misc. Metal"

1.02 References

- A. American Society for Testing and Materials (ASTM)
- B. American Welding Society (AWS)
- C. American Architectural Manufacturers Association (AAMA)

1.03 Submittals

- A. General: Submit the following in accordance with conditions of contract and Division 1 specification Section 01600.
 - B. Shop drawings in sufficient detail showing layout of sunshade device specified including manufacturer's specifications and installation requirements.

1.04 Quality Assurance

- A. Structural Requirements: Design, fabricate and install to support loads of related components as required for provisions for deflection, expansion and contraction forces.
- B. AWS D1.2: Certify that each welder employed in fabrication of work of this section has satisfactorily passed all AWS qualification tests for welding processes involved.
- C. SMACNA Standard: Comply with SMACNA "Architectural Sheet Metal Manual".

1.05 Delivery, Storage, and Handling

- A. Deliver materials to the project site ready for use and fabricated in as large sections and assemblies as practical, in unopened original factory packaging clearly labeled.

PART 2 PRODUCTS

2.01 Manufacturers

- A. ASCA, Inc., Portsmouth, NH (603) 433-6700.
- B. Substitutes to receive ten (10) day pre-bid

approval, from the architect of record.

2.02 Materials

- A. General: Metal shall be free from defects impairing strength, durability or appearance.
 1. Aluminum - ASTM B 221, alloys 6063-T5 and 6063-T6 for extrusions. ASTM B 209, alloys 5052-H32 or greater.
 2. Fasteners - Unless otherwise noted, fastener devices shall be 300 Series non-magnetic stainless steel. ASTM A-307, Grade A or better.

2.03 Components

- A. Sunshade baffles shall be 6063-T5 extruded aluminum ASCA configurations as indicated, spaced and sloped for 100% solstice sun cut-off for location and southern orientation.
- B. Outrigger's shall be 5052-H32 aluminum plate tapered and sculpted as indicated within the drawings. Outriggers shall be provided fully prepared for immediate installation.
- C. Sunshade fascia shall be 6063-T5 extruded aluminum ASCA configuration as indicated within the drawings provided in as continuous lengths as possible.
- D. Intermediate supports and outriggers shall be provided as required for applicable loading.
- E. Include stainless steel anchor hardware and accessories required for complete assembly.
- F. Components shall be completely shop assembled allowing immediate installation.

2.04 Finish - (choose)

- A. Shall be Fluorocarbon Custom 2-Coat System: Custom 2-coat, non-exotic thermocured system, composed of special inhibitive primer and fluorocarbon color topcoat containing not less than 70 percent polyvinylidene resin by weight, complying with AAMA 605.2.
- B. Class I, Clear Anodic Finish: AA-M12C22A41 (Mechanical Finish: nonspecular as fabricated Chemical Finish: etched, medium matte; Anodic Coating: Architectural Class I, clear coating 0.018 mm or thicker) complying with AAMA 607.1.

PART 3 EXECUTION

3.01 Examination

- A. Verification of conditions: Examine areas and conditions under which work is to be performed and identify conditions detrimental to proper or timely completion.
- B. Do not proceed until unsatisfactory conditions have been corrected.

3.02 Preparation

- A. Surface preparation: Prior to installation, clean substrate to remove, dirt, debris, and loose particles. Perform additional preparation procedures as required by manufacturer.
- B. Protection: Take all necessary steps to prevent damage to material during installation as required by manufacturer.

3.03 Installation

- A. Comply with manufacturer's instructions and recommendations for installation of the work.
- B. Verify dimensions of supporting structure at the site by accurate field measurements so that the work will be accurately designed, fabricated and fitted to the structure.
- C. Anchor Sunscreen to building sub-structure as indicated on the architectural drawings.
- D. Erection Tolerances:
 1. Variations from level: +/- 1/8" maximum in any column to column space.
- E. Do not cut and trim component parts during erection without the approval of ASCA.
- F. Do not erect deformed or otherwise damaged or defaced members. Remove and replace any members damaged in the erection process as directed.
- G. Set units level, plumb, and true to line, with uniform joints.

3.04 Cleaning

- A. Clean the exterior surfaces of the sunshades at regular intervals to prevent the buildup of dust and debris in accordance with AAMA . 610.1-1979 - Voluntary Guide Specifications.

3.05 Protection

- A. Protect installed materials to prevent damage by other trades.



Sir Norman Foster



Davis Brody Bond



LPA Architects



Gossen, Gasaway & Holloway

ASCA INC.

www.asca-design.com

PO Box 1140 • Portsmouth, NH 03802 USA
603.433.6700 • 603.433.3349 Fax
info@asca-design.com